

# LEVO

## Truck Mounted Elevated Platform





# Welcome to the **LEVO**OLUTION

## Designed in India, Built for the World

Discover the power of LEVO's Aerial Work Platform. Engineered for unmatched versatility and steadfastness, these platforms grant safe and effortless access to towering heights.

## Why choose LEVO?

- Whether it's rough worksites or narrow urban laneways, LEVO handles it with ease. Built tough to suit International roads and job sites—no compromises.
- With working heights from 11m to 24m, LEVO gives you the reach you need without the complexity of large machines. Quick to set up, easy to operate, and always reliable.
- Being mobile-elevated means you drive in, get the job done, and head to the next site—no waiting around for transport or trailers.
- You're not just buying a machine—you're backed by a team that understands your work. Spares and services you can count on.

## Standards



High strength  
structural  
steel



EN280-1:2022



CE Certified



BS Approved  
Design



IP67 Protection



Electro-  
Proportional  
System

## Accessories

- FRP Basket
- Aluminum Basket
- 110V / 230V Socket
- Inverter
- Working light in basket
- Hour meter
- Motion Alarm



# Key Highlights

## **Strenx® 700 High-Strength Steel**

Made with Strenx® 700 for superior strength-to-weight ratio, enabling lighter, more durable designs with increased load capacity and efficiency.

## **Innovative Hinged Telescopic Design**

Engineered with a hinged telescopic boom for best-in-class vertical reach, horizontal outreach, and up-and-over access.

## **Designed for Maximum Access**

Our articulating design offers seamless 360° operation, ensuring unmatched flexibility and reach.

## **Smart Telematics & Remote Diagnostics**

Integrated IoT-based telematics enables real-time monitoring, remote diagnostics, and smarter fleet management for enhanced uptime and efficiency.

## **Proportional Hydraulic Control**

Advanced proportional hydraulics deliver smooth, precise control for enhanced safety, efficiency, and performance.





# Kit Solutions

Gemini offers LEVO kits for articulated Mobile Elevated Work Platforms (MEWPs) with working heights ranging from 11 to 24 metres. Designed for easy integration, our kits are ideal for locally sourced truck chassis (GVW above 2.5 tonnes) and comply with regional road and safety standards.

Each kit features either fully hydraulic or electro - proportional controls, ensuring a streamlined installation process. Comprehensive manuals and optional enhancements — like 1100V insulated fibre cages, aluminium platforms, and platform inclinometers — help meet diverse operational requirements.

To support seamless integration, Gemini provides subframe engineering assistance on request. With LEVO kits, dealers and bodybuilders across Australia, New Zealand, and the Pacific can deliver reliable, high-performance, and regulation-compliant EWP solutions.

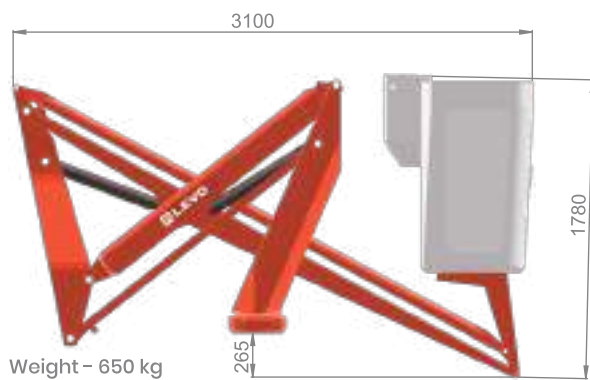

**LEVO 11**



**LEVO 14**



**LEVO 24**



# Key Dimensions

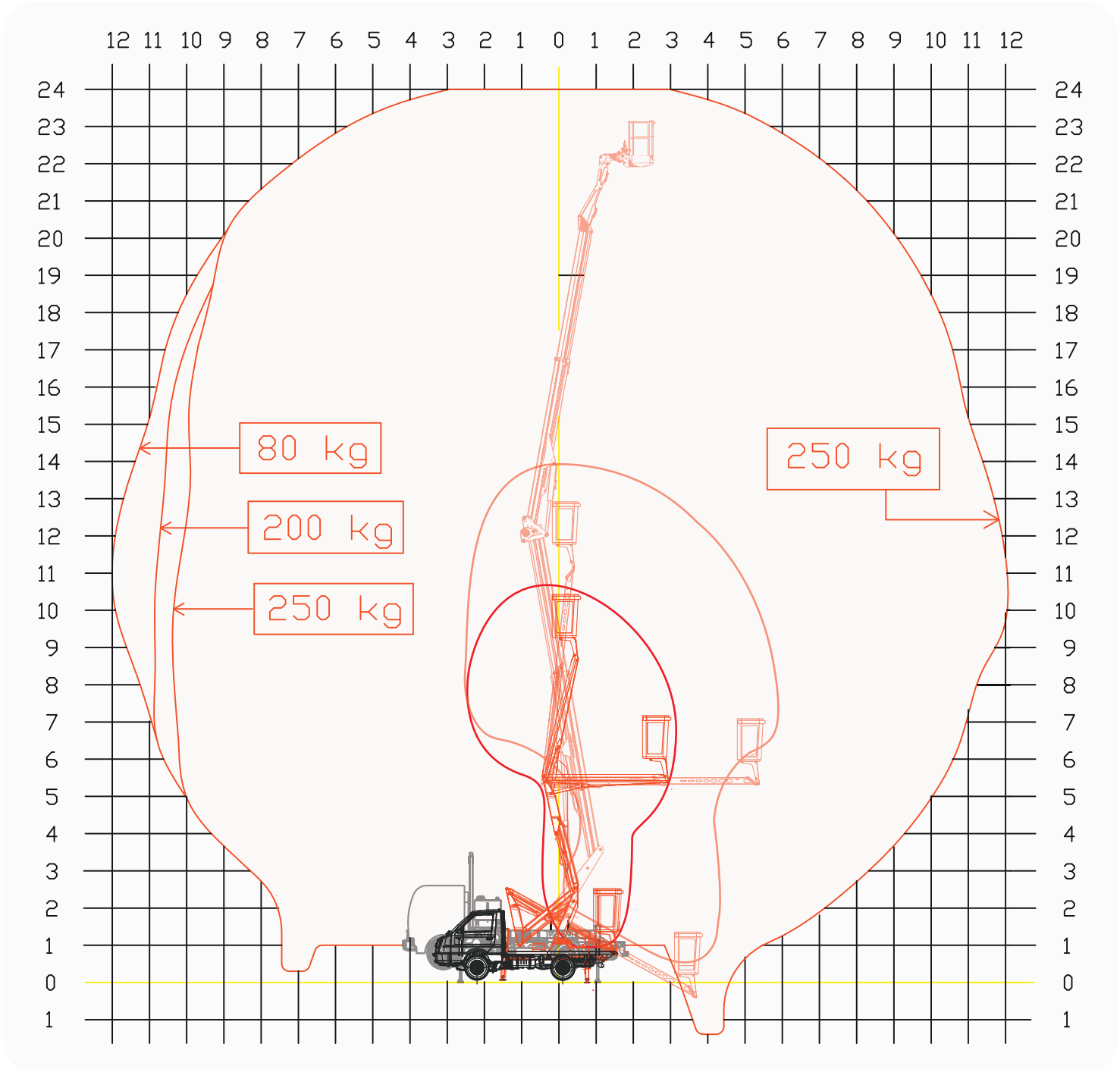



# Specifications

	LEVO 11	LEVO 14	LEVO 24
 Working Height (m)	11	14	24
 Platform Height (m)	9	12	22
 Safe Working Load (kg)	200	200	250
 Horizontal Outreach (m)	3.6	6	12.5
 Turret Rotation	360°	360°	360°
 Basket type	Fibre glass	Fibre glass	Aluminium
 Stab type	A type	A type	H type
 Basket Dimensions (m)	1.1 X 0.7 X 1.1	1.1 X 0.7 X 1.1	1.1 X 0.7 X 1.1
 Maximum Wind Force (m/s)	12.5	12.5	12.5
 Number of Stabilizers	4	4	4



# Salient Features



## Basket

Standard FRP basket with 3 kV insulation; aluminium option also available on request.



## Boom Construction

Precision robotic welding ensures structural integrity, while powder-coated booms offer long-lasting protection and a premium finish.



## Precision Hydraulics

High-performance hydraulics built with premium materials and precision machining for superior functionality and stability.



## Proportional Systems

Advanced proportional hydraulics deliver smooth, precise control for enhanced safety, efficiency, and performance.



## IOT and AI Enabled

Enabled with remote diagnostics, telematics, real-time data monitoring, and intelligent error detection for smarter operations.



## Precision Hydraulics

Designed for minimal downtime and hassle-free servicing, with easy access and readily available spare parts.



Member



## Gemini Power Hydraulics Private Ltd

**Head Office**  
Gemini House,  
Bus Depot Lane,  
Deonar, Mumbai,  
Maharashtra 400088,  
India

**Factory**  
D222/27  
MIDC Nerul,  
Navi Mumbai,  
Maharashtra 400706,  
India

**Contact**  
☎ +91 22 66819999  
☎ +91 98330 28000

**Contact**  
info@geminiindia.com

